

REVISION HISTORY			
REV.	DESCRIPTION	SIGNATURE	DATE
A	DRAWING RELEASE		11/1/93
-	-		-

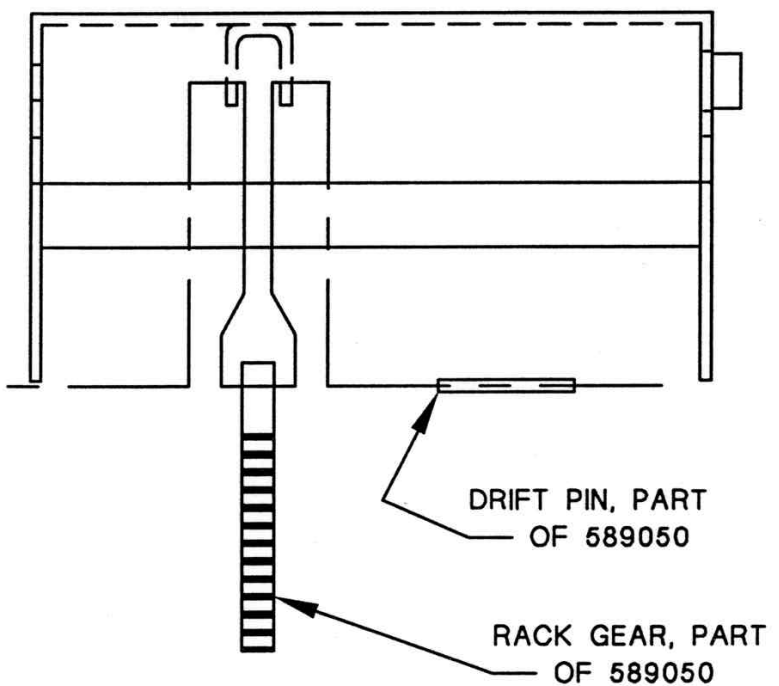
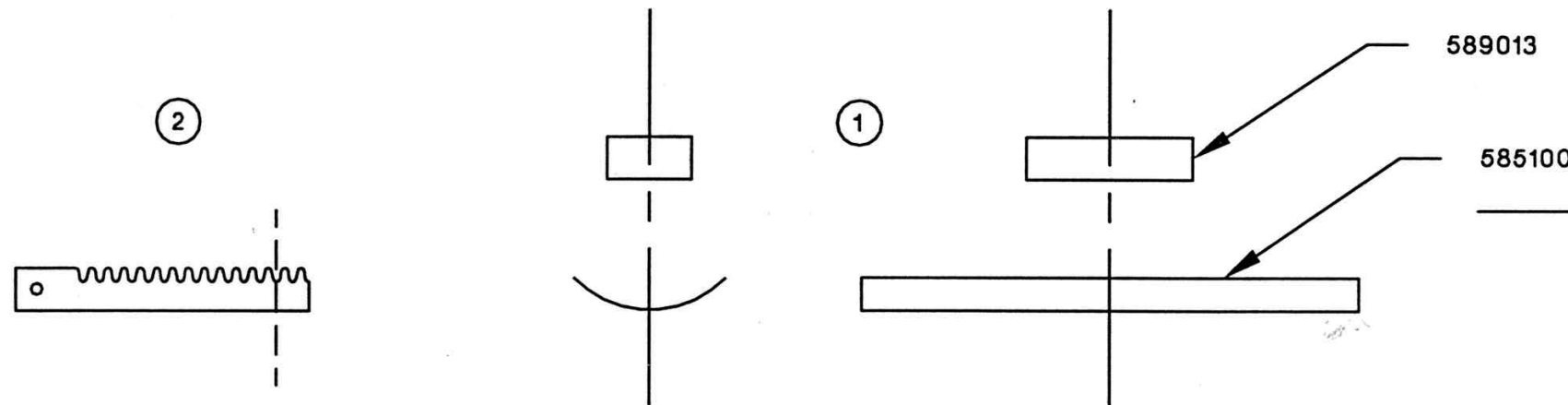
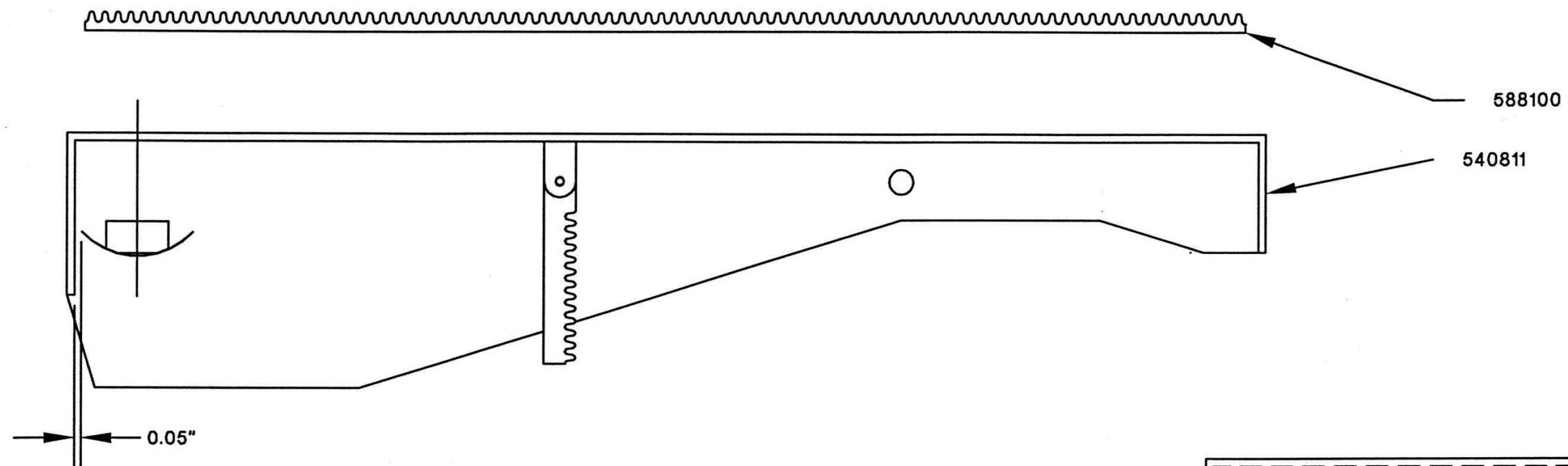

NOTES:

1. APPLY THE DOUBLE SIDED FOAM TAPE TO THE STEEL TAPE, AS SHOWN.
2. USING SIDE CUTTERS, CUT OFF THE LAST TWO TEETH ON THE RACK GEAR.
3. USING THE DRIFT PIN, INSTALL THE RACK GEAR IN THE TOP OF THE PEDAL.
4. LOCATE THE STEEL/FOAM TAPE ASSEMBLY IN THE CENTER (LEFT TO RIGHT) OF THE PEDAL TOP, 0.05" FROM THE BACK EDGE. PRESS INTO PLACE.
5. PRESS THE RUBBER PAD ON TO THE TOP OF THE PEDAL, EQUALLY SPACED FROM ALL EDGES.

THIS DRAWING DOCUMENT CONTAINS INFORMATION WHICH IS PROPRIETARY TO AND THE PROPERTY OF ADA, INC. AND MAY NOT BE USED, REPRODUCED OR DISCLOSED IN ANY MANNER WITHOUT THE EXPRESSED CONSENT OF ADA, INC.		ADA SIGNAL PROCESSORS, INC. 420 LESSER STREET, OAKLAND, CA 94601	
FILE NAME: A932A.DWG	TITLE: CCP, CHASSIS TOP SUB-ASSEMBLY		
CHECKED BY:	DRAWN: D.WIRT	SIZE: A	DRAWING NO. 932
DATE:	ENGR:	SCALE:	REV: A
APPROVED BY:	DATE: 11/1/93	SHEET 1 OF 1	
DATE:	© COPYRIGHT 1993		